



B-R Controls Pty Ltd

Unit 3, 95 Hunter Street
HORNSBY NSW 2077
Australia

Telephone: (+61) (02) 9476 2133
Facsimile: (+61) (02) 9476 2688
E-mail: mail@brcontrols.com.au
Website: www.brcontrols.com.au

DIODE ARRAY PROCESS ANALYZER - FOR SULFUR RECOVERY

Aaron J. Rollo
Applied Analytics, Inc.
4 Clock Tower Place,
Maynard, Massachusetts, 01754

KEYWORDS

Sulfur Recovery, H₂S, UV, Spectroscopy, Diode Array, Tail Gas

ABSTRACT

Legislation enforcing emission control of toxic substances has now been passed worldwide.³ An important subgroup of such substances is comprised of the sulfur-based compounds; sulfur recovery units are a critical component of the processes of oil refining and liquefying natural gas. Fast, accurate, and continuous analytical techniques are necessary to comply with these regulations, and to improve efficiency in sulfur recovery processes.

A variety of recovery processes are normally operated at a single plant; using a single type of analyzer for a majority of applications guarantees better technical support and a higher level of expertise in plant operators.

This paper reviews the utilization of spectroscopy in step with diode arrays, a time-tested, industry-accepted technology for sulfur recovery applications.

One analyzer with different sampling systems can be used for a variety of applications. Common applications include Hydrogen sulfide (H₂S), Tail Gas, Natural Gas and Mercaptans.

INTRODUCTION

Petroleum (oil), gas and coal all contain sulfur to some extent, and need to be purified prior to being distributed to the consumer. Table I shows sulfur recovery applications utilizing dispersive Ultra Violet (UV) Absorption techniques. Table II shows Sulfur Dioxide (SO₂) emissions from Natural Gas, Oil, and Coal.

TABLE I: SULFUR RECOVERY APPLICATIONS UTILIZING UV ABSORBANCE TECHNIQUES

APPLICATION	COMPONENT TO MEASURE AND CONCENTRATIONS	PHASE
H2S in 'sweet gas'	H2S 0-10PPM	Gas
Pre SRU	H2S 0-100%	Gas
Tail gas	H2S 0-2%, SO2 0-1%; COS&CS2 0-2000PPM; Sv	Gas
Mercaptans & H2S in natural gas	H2S PPM RSH %	Gas
SO2 and ammonia in stack	SO2 0-500 PPM NH3 0-10 PPM	Gas
Sulfur in oil	Total Sulfur 0-10 PPM	Liquid (head space to be measured in the gas phase)
H2S in water	0-10 PPM	Liquid

TABLE II: FOSSIL FUEL EMISSION LEVELS IN POUNDS PER BILLION BTU OF ENERGY INPUT (SOURCE: EIA - NATURAL GAS ISSUES AND TRENDS 1998) ²

POLLUTANT	NATURAL GAS	OIL	COAL
SULFUR DIOXIDE	1	1,122	2,591

NATURAL GAS

Raw natural gas contains, among other impurities, hydrogen sulfide. Gas containing H₂S above a certain concentration limit (1%) is known as 'sour gas.' The process for removing hydrogen sulfide from sour gas is referred to as 'sweetening' the gas. Gas sweetening commonly utilizes the amine process, in which amine solution absorbs the sulfur from the natural gas. The amine solution is then regenerated by heating and degassing the H₂S out, allowing the solution to be reused in the amine absorber. The sour gas coming out of the recycled amine unit contains high amounts of sulfur and requires further processing. This gas is fed into a Claus process resulting in oxidation to elemental sulfur. The sweet clean gas, distributed to the end user – known as 'sales gas' – is restricted to an H₂S content of 4 PPM.

OIL

The Tier 2 emission standard ³ for cars under the Clean Air Act requires that the average concentration of sulfur in gasoline be lower than 30 PPM (the previous limit was 500 PPM). In 2006 refiners were required to produce ultra-low sulfur fuel (ULSD), where the highway diesel fuel limit is lower than 15 PPM.

The global increase in energy demand ¹ often requires the industry to exploit resources that contain higher amounts of sulfur. This, in addition to the strict regulations, causes an increase in sulfur

recovery processing. The petroleum refiners and natural gas plants need to further optimize processing in a cost-effective way.

Process analyzers provide critical information both for process control and for verification of compliance, and are instrumental in this optimization process.

INSTRUMENTATION

The Applied Analytics OMA-300 and TLG-837, both UV-VIS fiber-optics-diode-array process spectrophotometers, are used to measure the absorbance of the process sample.^{4,5,6,7,8}

The analyzers consist of four major subunits:

- a light source that generates electromagnetic radiation
- a sample area (flow cell or in-situ probe)
- a dispersion device that selects a particular wavelength from the broad band radiation of the source (concave holographic grating)
- a diode array detector to measure the intensity of radiation at each wavelength

Light that is generated by the pulsed Xenon light source is transmitted through a fiber optics cable to a flow cell or probe, where the process gas absorbs some of the light at a certain wavelength. The absorbance of the process gas in the flow cell is directly proportional to the concentration of the component to be measured. From the flow cell, the light travels through another fiber optics cable to the detector. The white light is first dispersed by a holographic grating, resulting in a physical separation of the white light into its components. The light at each wavelength falls onto a different detector - the diode array contains 1024 detectors - and a spectrum (the light intensity or absorbance at each wavelength) is obtained. This process is rapid and no moving parts are involved in the measurement. See Figure 1.

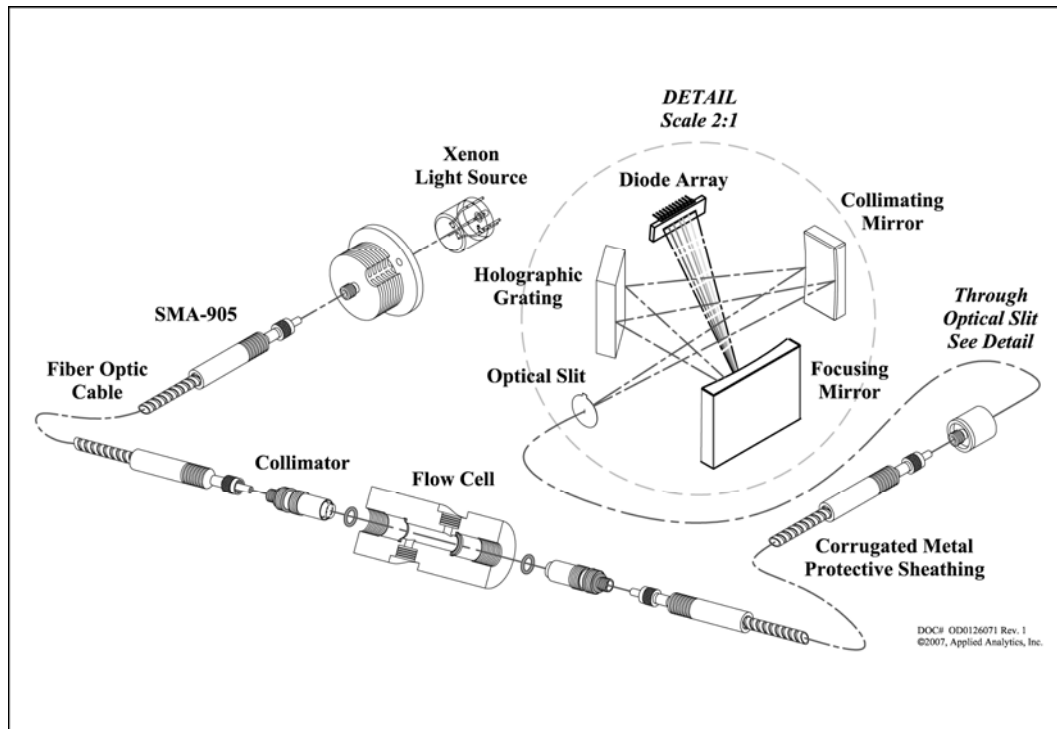

FIG 1: A DISPERSIVE BASED ANALYZER MEASURING SIMULTANEOUSLY FROM 190-800 NM AT 0.7 NM RESOLUTIONS.

THE DETECTOR

The detector is a high-resolution UV/VIS photodiode array. The diode array has a broad spectral response and high sensitivity in the ultraviolet range. The low dark current and large charge saturation enables signals to be obtained with a high signal-to-noise ratio. The detector's aperture matches the fiber optics numerical aperture, maximizing the light throughput.

THE LIGHT SOURCE

The light source is a very long-life, pulsed Xenon lamp. The light source is imaged on the fiber tip with numerical aperture-matching optics rather than a direct couple, for maximum light throughput, and minimum pulse-to-pulse variation.

THE FLOW CELL

The gas or liquid stream interacts with light coming from the Xenon light source, in a flow-through cell that is connected either directly to the process line or through a sampling system. Fiber optics connect to the flow cell via a modular collimating lens unit. The length of the flow cell used is between 1mm and 1000mm. The flow cell can be operated up to 300°C and at pressures as high as 206 Bar (3000 psi). The flow cell design allows for very quick disassembly resulting in minimal downtime for routine maintenance.

Flow cell path length is optimized for each application. When choosing the flow path, one needs to consider the following: the longer the path, the higher the absorbance signal (allowing for measurement of low level H₂S, for example); transmitting light in the low UV through a long flow cell is a challenge, however. In order to measure in the 210 nm range using a long (1 meter) flow cell, the optics must be perfectly aligned and designed for maximum light throughput in the low UV.

UV ABSORBANCE SPECTROSCOPY

The sulfur-based components in the sulfur recovery applications - namely H₂S, SO₂, mercaptans (RSH), carbonyl sulfide (COS) and Carbon disulfide (CS₂)- all show noticeable UV absorbance spectra. Moreover, the spectra are sufficiently different to allow for multi-component measurement.

The absorbance at a specific wavelength can be correlated to concentration. The extinction coefficients at each wavelength are different. According to Beer-Lambert's law, the absorbance at a specific wavelength is equal to the extinction coefficient of the specific molecule at a specific wavelength, multiplied by its concentration and path length.

The extinction coefficient is a characteristic of a given substance at a specific wavelength. The structure of the absorbance spectrum of a substance is determined by the level of absorbance of that substance at each wavelength.

Correlation factors between absorbance and concentration are determined in the calibration process. The correlation factors at each wavelength depend on path length and the extinction coefficients of that specific molecule.

MULTI -WAVELENGTH, MULTI -COMPONENT ANALYSIS

The term multi-component analysis is used to describe procedures in which several components are determined simultaneously. A variety of powerful mathematical tools^{7,9,10,11} can be applied to the analysis of spectroscopically generated data.

Multi-wavelength and multi-component analyses are feasible with this technology, since an entire (190-800 nm) high-resolution spectrum is measured and processed. The same analysis method is utilized in both single and multi-component applications.

APPLICATION VARIABLES

A wide range of concentrations and components can be measured by varying the flow cell path length, wavelength measurement range (an at-site, user-defined parameter), operational pressure, and sampling system. Applications in which the pressure and temperature vary require that these stream variables be monitored and compensated for in the concentration readings.

WAVELENGTH RANGE

The method's wavelength range is set per application. The optimal range for low PPM H₂S is 215-225 nm (see Figure 2) whereas for the percent level H₂S it is 230-240 nm (see Figure 3). In method development, one must consider the following: though light throughputs are lower in the low UV making it a more difficult range to work at, the absorbance signals are usually higher (greater sensitivity) in the lower UV allowing for lower detection limits. Figure 2 shows H₂S in % levels.

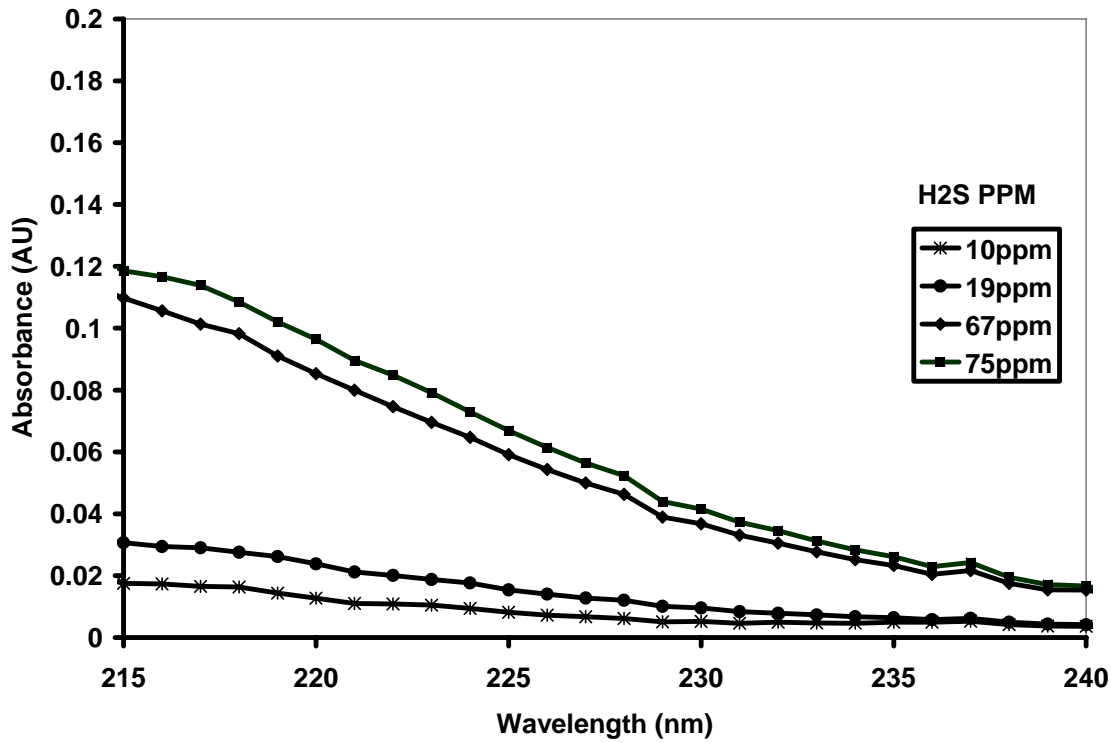

FIGURE 2: UV ABSORBANCE SPECTRA OF H2S PPM LEVELS

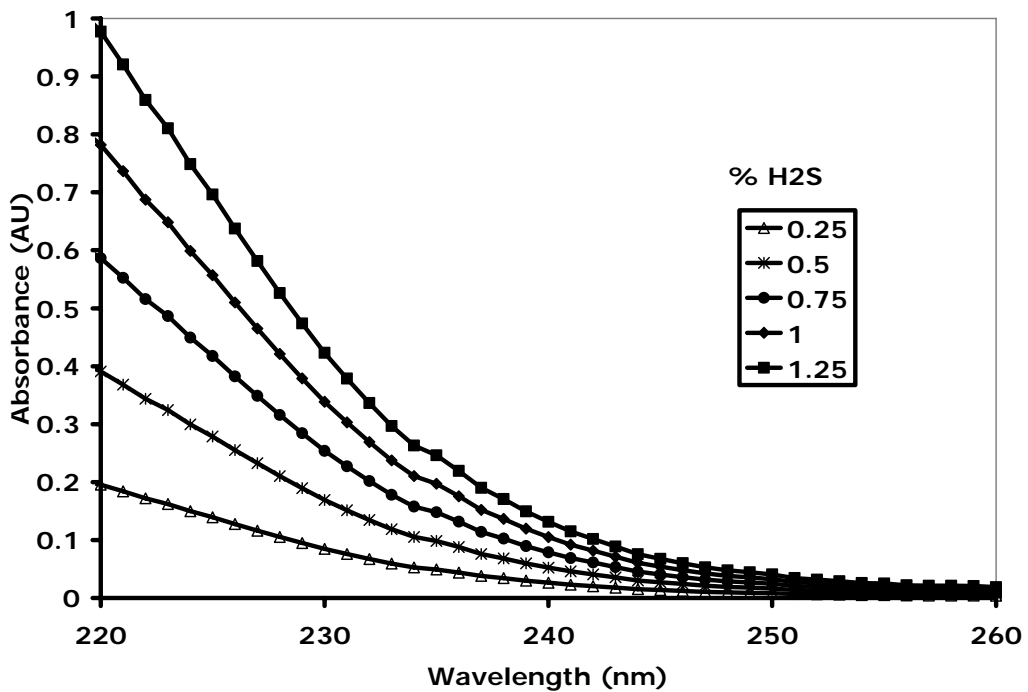

FIGURE 3: UV ABSORBANCE SPECTRA OF H₂S % LEVELS

APPLICATIONS

H₂S IN SALES GAS

Purified sales gas needs to be monitored for H₂S content prior to being fed into the pipeline to the end-user markets. To adhere to the strict environmental regulations for H₂S concentration, monitoring at sub-PPM levels is essential. The spectroscopic approach allows for a direct method that does not involve any separation, sample preparation, or the use of additives, and utilizes a high-resolution, high-signal-to-noise, low-stray-light process spectrophotometer.

Processing high-resolution spectra rather than using a few low-resolution bands such as in a filter-based photometer, is critical in this application, since the quality of the data is of utmost importance to the process control. In contrast, a filter instrument measuring at a limited and low-resolution band is very sensitive to noise.

H₂S 0-100%; PRE SULFUR RECOVERY UNIT (SRU) ANALYZER

The same analyzer can be also used for the monitoring of 0-100% H₂S. The signals coming from this analyzer are used to control the air input to the sulfur recovery (feed-forward control) and for evaluation of the process' effectiveness. The method's wavelength range is higher, and a shorter flow cell is used. Figure 4 shows a trend graph from the Distributed Control System (DCS).

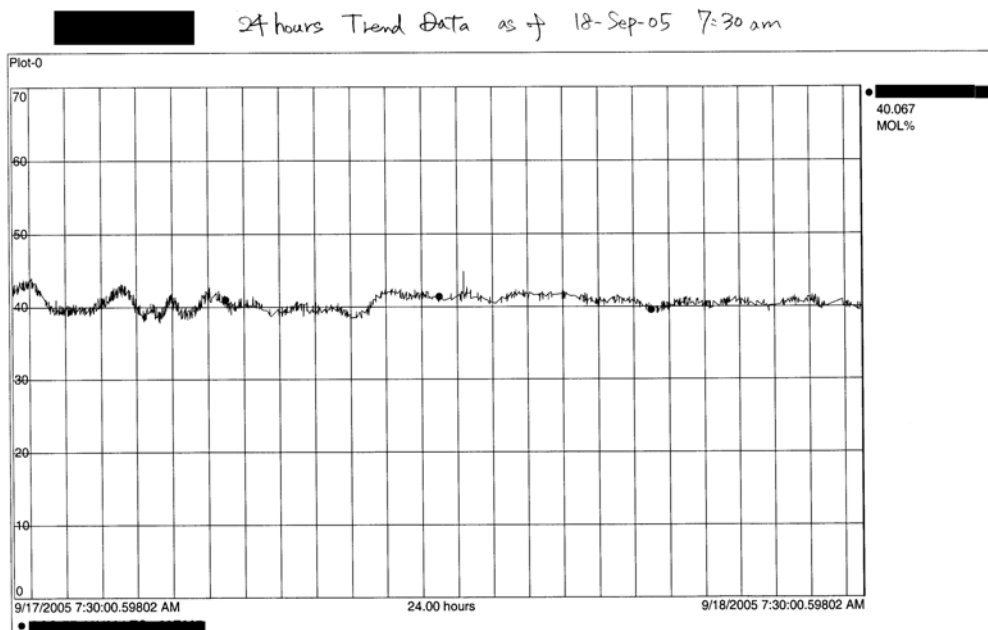

FIGURE 4: ACID GAS 24 HOURS TRENDS GRAPH, MONITORING HIGH % LEVEL H₂S

CLAUS TAIL GAS APPLICATION

Tail gas is another important multi-component application. The Claus sulfur recovery process is commonly utilized for the removal of sulfur compounds from sour gas. The process is optimized when the correct stoichiometric ratio of H₂S to SO₂ is achieved. The efficiency of the recovery process

depends on accurate measurements of the H₂S to SO₂ ratio. To obtain this accuracy, other stream components such as CS₂, COS, and sulfur vapor need to be taken into account.

THE PROCESS REACTIONS:

1. Reaction furnace:

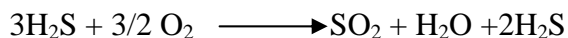

2. Catalytic converters:

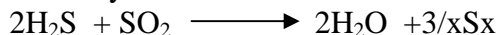

PROCESS CONTROL

Typically, the H₂S to SO₂ ratio should be 2:1 for efficient conversion. The Feedback control parameter (air-demand) is equal to 2[SO₂]-[H₂S] and the process is optimized when the air-demand equals zero. Other similar processes require different ratios; the full-spectrum analyzer allows for wide concentration dynamic range and therefore can easily be applied to the control of other possible ratios. The control formula is a user-defined parameter.

THE ANALYZER

The analyzer's design⁸ adheres to the principle of no moving parts and no sample lines in sulfur recovery applications. The same diode array analyzer is utilized here, but an in-situ probe is used in place of the typical flow cell.

DEMISTER "COLD FINGER" PROBE

A patent-pending demister ("cold finger") probe is used for in-situ measurements. The setup requires very low maintenance, benefiting from the innovative in-situ probe (See Figures 5 and 6). The probe is designed to draw a continuous sample into its body, and remove the sulfur vapor. This is done by a "cold finger" which condenses the sulfur out of the gas in a controlled manner, and an aspirator, which draws the sample into the sample chamber, and returns it to the process line.

The probe is constructed from three concentric tubes. The outer tube, called the "sample chamber", is 1.5" in diameter. This tube passes down through a ball valve into the process line, where its angled tip helps draw the tail gas into the chamber. The cold finger tube located inside the sample chamber is kept much cooler than the process gas. This causes most of the sulfur to condense and drip back into the process, creating a sample stream that is free of sulfur vapor. Cooled air is constantly fed to the bottom of the cold finger through a smaller internal tube and is exhausted out the opposite side. These three tubes are welded to the first section of the probe's head, a 1" thick disk made of 316 stainless steel. Above this is a second disk, which contains an air-driven aspirator. This provides a vacuum, which draws the process gas into the sample chamber, past the cold finger, and up through an integrated flow cell at the top of the probe head. The aspirator then pulls the sample down through a waste tube, where it is exhausted back into the process.

All air/gas connections in the head are 1/4" Swagelok tube fittings. These accommodate the aspirator air in, cold finger air in and out, and calibration gas in. The integrated flow cell has fiber optic connections on each side. The system periodically washes and zeros itself. Calibration gases can be introduced into

the probe at any time for data verifications, although recalibration or spanning is not required, since it is a solid-state analyzer.

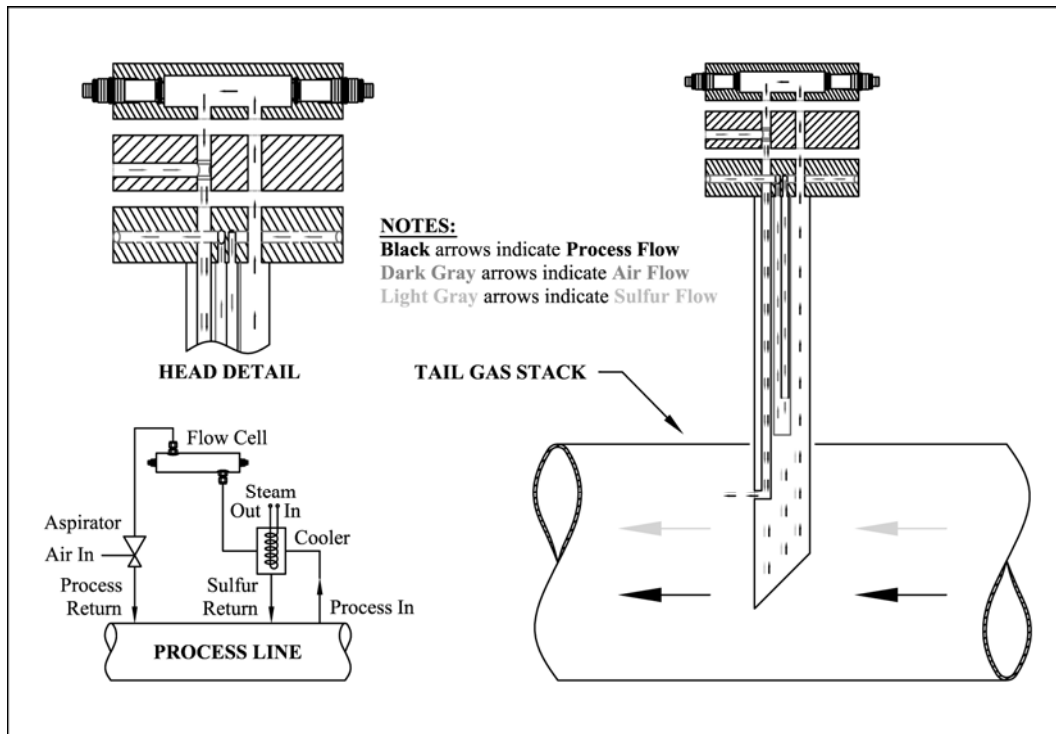

FIGURE 5: SCHEMATIC DIAGRAM OF THE PATENT-PENDING “COLD-FINGER” PROBE (PATENT- PENDING)



FIGURE 6: INSTALLED TAIL GAS PROBE AND FIBER OPTICS GOING BACK TO THE ANALYZER (PATENT- PENDING)

TAIL GAS ANALYZER - UV ABSORBANCE SPECTRA

The concentrations of up to five components are measured: H_2S and SO_2 for process control, COS and CS_2 for catalyst efficiency, and sulfur vapor for signal compensation. Each one of these components has unique UV absorbance spectra. Figures 3 and 7 show the absorbance spectra of H_2S and SO_2 at

different concentration levels. Figure 8 shows the total signal of a mix of 1% H₂S and 1% SO₂ and the individual signals. The absorbance spectra of the individual components are superimposed to give the total absorbance spectrum of the process sample (see Figure 9). To de-convolute the signals of each of the components, a full-spectrum, multi-component algorithm is used.

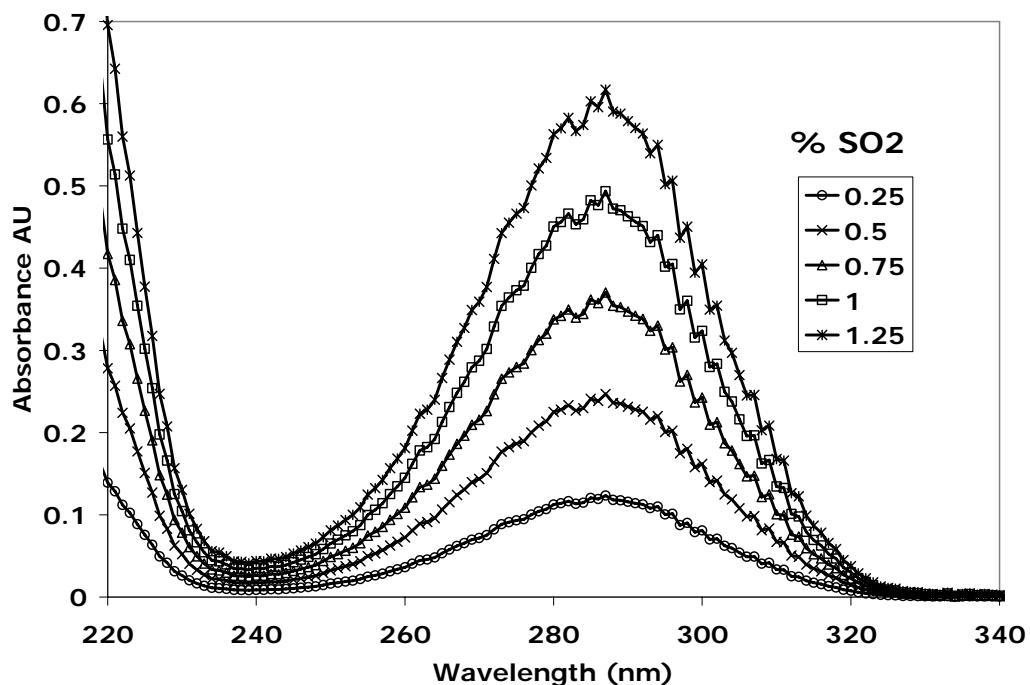

FIGURE 7: ABSORBANCE SPECTRA OF SO₂%

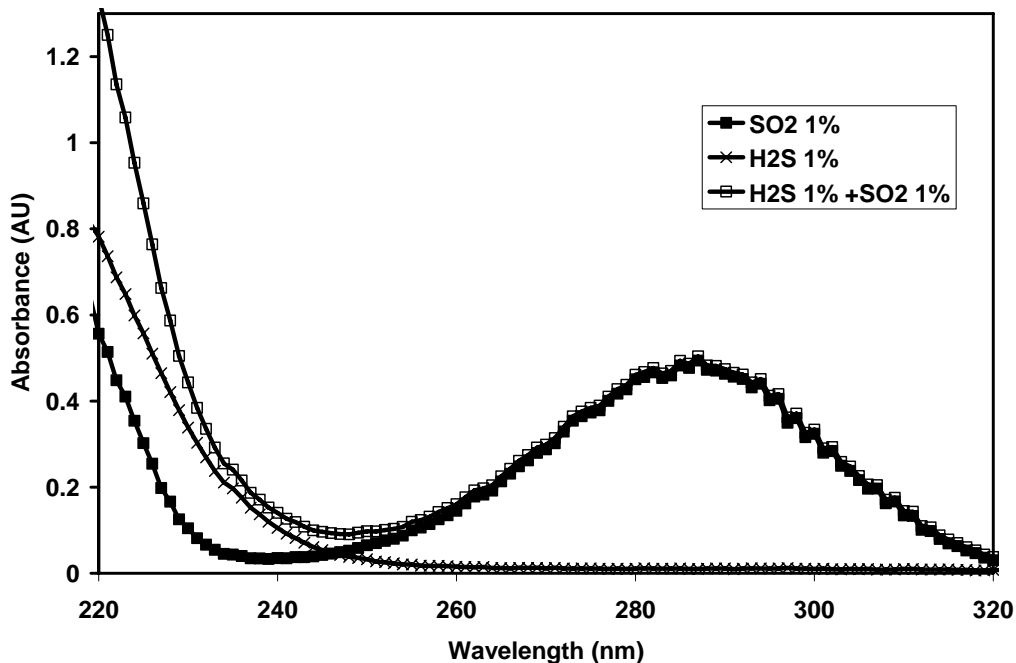

FIGURE 8: TOTAL SIGNAL ABSORBANCE OF A MIX OF 1% H₂S AND 1% SO₂ AND THE INDIVIDUAL ABSORBANCE SIGNALS.

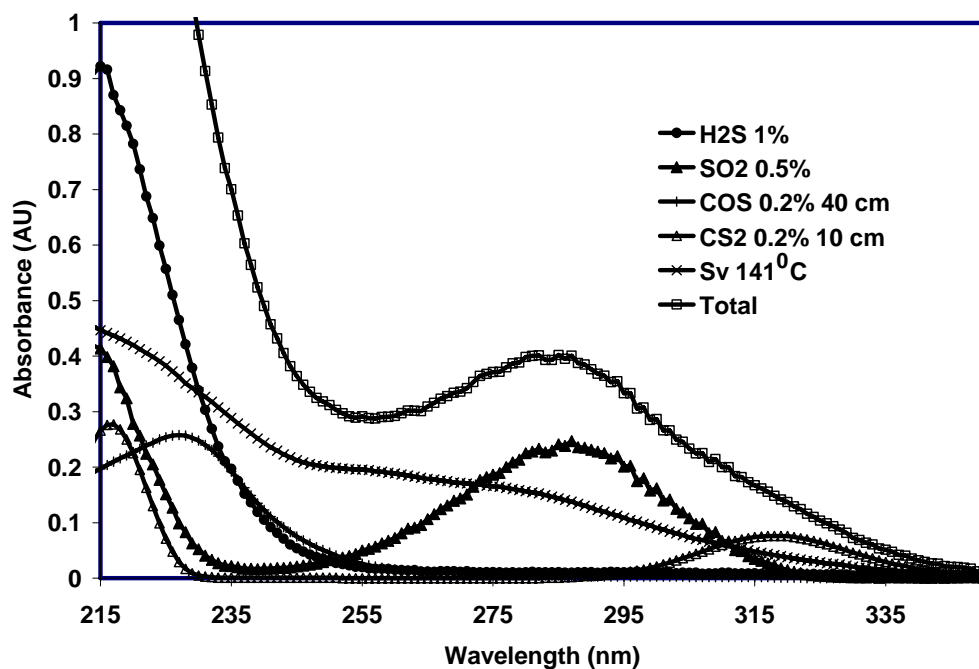

FIGURE 9: TAIL GAS ABSORBANCE SPECTRA; INDIVIDUAL COMPONENT'S SPECTRA ARE SUPERIMPOSED TO GIVE THE TOTAL ABSORBANCE SPECTRUM OF THE PROCESS SAMPLE

CONCLUSION

Utilizing a high-resolution (1 nm) wide-dynamic-range (190-800nm) spectrophotometer allows for the measurement of different components, various concentration ranges, and single or multi-component streams with a single type of analyzer. Moreover, the ability to change an application in the field - to add or delete a specific component from the method once the analyzer is already installed - is of great benefit, particularly in new plant constructions where the streams to be monitored might vary from the initial designs.

The sampling system, flow cells or probes vary depending on application; the measurement principle is the same, however. UV has several major advantages: water is transparent at this range and does not interfere with the readings; H₂S, an important component, has a high extinction coefficient; UV allows the use of solid-state diode array detection, whereas other spectroscopic techniques such as IR, require mechanical scanning with more vulnerable and expensive systems such as FTIR.

In comparison to other analytical techniques for sulfur recovery analysis, the dispersive UV method does not require consumables such as lead acetate paper tape, or slow separation techniques such as GC. Implementing dispersive UV technology for process analysis is not trivial; various critical components needed to be optimized and novel design ideas were implemented, resulting in an extremely versatile analytical tool.

REFERENCES

1. Energy Information Administration, Official Energy Statistics from the U.S.A. “International Energy Annual (IEA) - long-term historical international energy statistics” (<http://www.eia.doe.gov/iea/>)
2. EIA National Energy Information Center (NEIC) “Natural Gas 1998: Issues and Trends”
3. U.S. Environmental Protection Agency, “ Tier 2 Vehicle & Gasoline Sulfur Program” (<http://www.epa.gov/tier2/>)
4. Yoav Barshad and Yael S. Barshad, Incoming Materials Validation by UV/VIS/SWNIR Absorbance; An On-line Recognition Method, JPAC, Vol.7 - 2
5. Barshad Y, UV-VIS Spectrometer - *On-Line Diode-Array UV/VIS Fiber Optic Spectrometer for Composition Monitoring.*, Measurements & Control, June 1992
6. Barshad Y. S. and Barshad Y., *The Spectrophotometer*, Precision Cleaning, May, 1999
7. Barshad Y., *A New Breed of Versatile Diode Array Analyzer Systems; A Tool for Multicomponent Analysis.* BIRA Conference Antwerpen March 25, 1993.
8. Barshad Y., *A Sulfur Recovery monitoring system using state-of-the-art fiber optics diode array analyzer*, Sulphur Tampa (British Sulfur), p143-151, November 1994.
9. Mark, H., *Principles and practice of Spectroscopic Calibration*, Chemical Analysis, Vol. 118, Wiley: New York, 1991.
10. Martens, H. and Naes, T., Multivariate Calibration, John Wiley & Sons, 1989.
11. *Standard Practice for Describing and Measuring Performance of Ultraviolet, visible and Near-infrared Spectrophotometers*, ASTM Standard E 275-83, 1994